



Intelligent Two-zone Infrared Cooker
智能雙頭電陶爐

Model/型號：EC-2330

Installation & Operating Instructions
產品使用說明書

CONTENTS

1	Product Introduction-----	2
	1.1 .Introduction of Product	
	1.2 .Function & Characteristics	
2	Installation Guideline-----	3-5
3	Control Panel Instructions-----	6
4	Operation Method-----	7-8
	4.1 .Operation Instructions	
	4.2 .Usable and Non-usable Cookware	
	4.3. Heating Power Distribution	
5	Safety Precautions-----	9
	5.1 .Safety Notes	
	5.2 .Warning	
6	Daily Maintenance-----	10
7	Product Specification-----	10
8	Trouble-Shooting Guideline-----	11
	8.1 .Code Of Breakdown	
	8.2 .Trouble Shooting	

1 、 Product Introduction

1.1 、 Introduction Of Product :

Thank you for choosing **Garwoods EC Infrared Cooker**. This product utilizes German EGO radiant heating element. The thermal efficiency is extremely high and reach 500-600°C in just a few seconds. It is controlled by the micro-computer touching sensor control system. Please read this operation manual carefully before installing or using this product.

1.2 、 Function & Characteristics :

- **Energy-efficient** : The infrared cooker utilizes radiant heating element for a brand-new calefaction principle. The thermal efficiency is extremely high. There is a high temperature remains on the surface for short-time cooking without power after cooking. It is energy-saving.
- **Multi-function** : The infrared cooker utilizes newest micro-computer chip program control. It offers multiple scales for heating power level regulation. Also, it offers timer; overheat protection; auto-temperature adjustment; high temperature indicator etc.
- **Safety & Environmental Friendly** : Safety & Environmental Friendly of the product is on our top priority. The infrared cooker contains a serious of safety system such as safety lock; high temperature indicator; automatic shut-off when 2 hours not in use; and auto-temperature adjustment.
- **Easy-to-clean Surface** : Ceramic glass top panel is easy to clean. When the high temperature indicator is off and the surface is cool down after cooking, wipe it with a damp cloth.

【Notice :The surface is under a very high temperature condition after cooking, please do not place any combustible materials on the surface and touch the surface to avoid any risk of fire and getting burnt】

- **Touch Buttons Operation** : Touch button design is easy for use.
- **Intellectual Power** : The cooker adopts intellectual power distribution technology and the specified power can be distributed to each cooker zone by the micro-computer system.

2、Installation Guideline

★ Installation should be followed below requirements：

- 1、The walls on top of the working face and next to the installation of infrared cooker must be heat-proof.
- 2、The laminated boards and adhesive used for installation must be heat-resistant.
- 3、For any installation method, the air under the cooker and behind the cooking range should have enough space for cooling in order to ensure the safety of operating the infrared cooker.
- 4、Based on the prescribed dimensions, a square hole is opened on the work table. Ensure the distance between any side of the work table and the walls is $\geq 100\text{mm}$.
- 5、Protect the opening: If in contact with damp, the laminated boards used in marking the work table will easily expand more. It is required to stick varnish or special adhesive onto the edge of the opening in order to prevent any steam from condensation under the work table.
- 6、For any condition of installation, the infrared cooker should have a good ventilation condition with air inlet and air outlet not blocked.
- 7、Don't place other equipment on the working face of the double cooking zones of the infrared cooker and within the range of 30cm around the working face.
- 8、If choosing a table-top installation, ventilation hole shall be at least 100mm from wall surface.
- 9、The infrared cooker must be complied with a 13A power outlet.

★ Steps on Installation：

~ Open an installation hole on the worktop of cabinet as per **【illustration 1】**.
(Note：The height shall be more than 100mm)

Cut out dimensions(unit/mm)：(W) 670 x (D) 350 x (H) 100

【illustration 1】

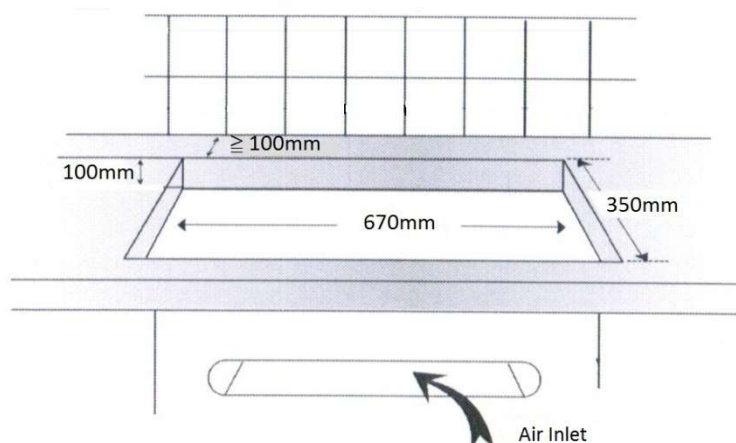

~ In front of the cabinet, open an air inlet with more than 100cm² under the location of infrared cooker as per 【illustration II】 . If the cabinet is not sealed, the air inlet may not be opened so as to ensure heat elimination.

【illustration II】

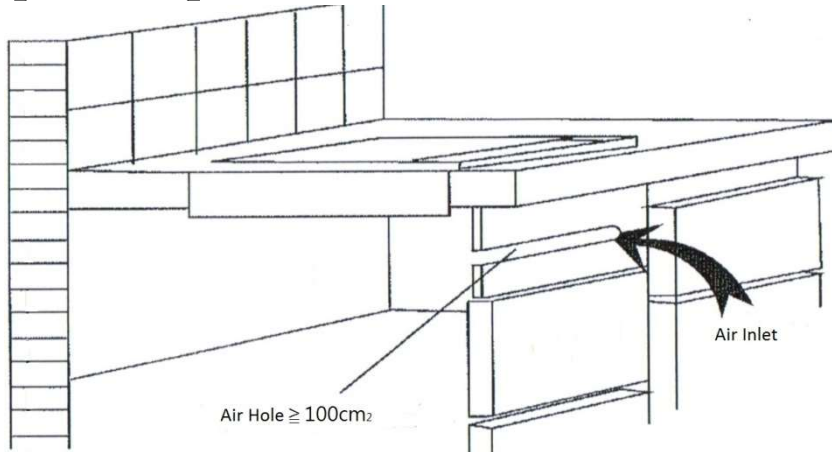

~ Before put the infrared cooker into the hole, an water-proof type is properly applied on the bottom of front panel of the infrared cooker as per 【illustration III】 . If the old size of the hole is large than the current size of cutting hole, a double side type can be used to fix the movement between infrared cooker and worktop.

【illustration III】

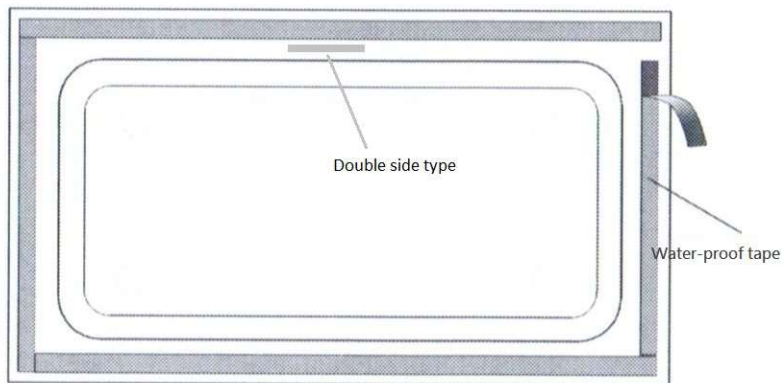

~ Put the infrared cooker into hole. Insert plug of power line into corresponding socket. The infrared cooker can be used after power connection as per **【illustration IV】** .

【illustration IV】

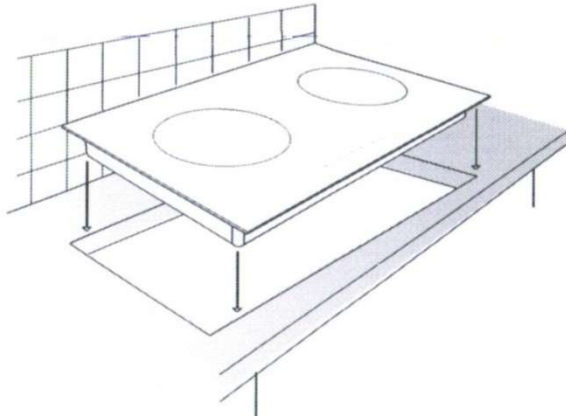

~ If the infrared cooker is installed above an oven, fix an insulation part at least 15cm under the infrared cooker as per **【illustration V】** . Also, open an air inlet with more than 100cm² under the location of the infrared cooker to ensure ventilation and operation in good conditions

【illustration V】

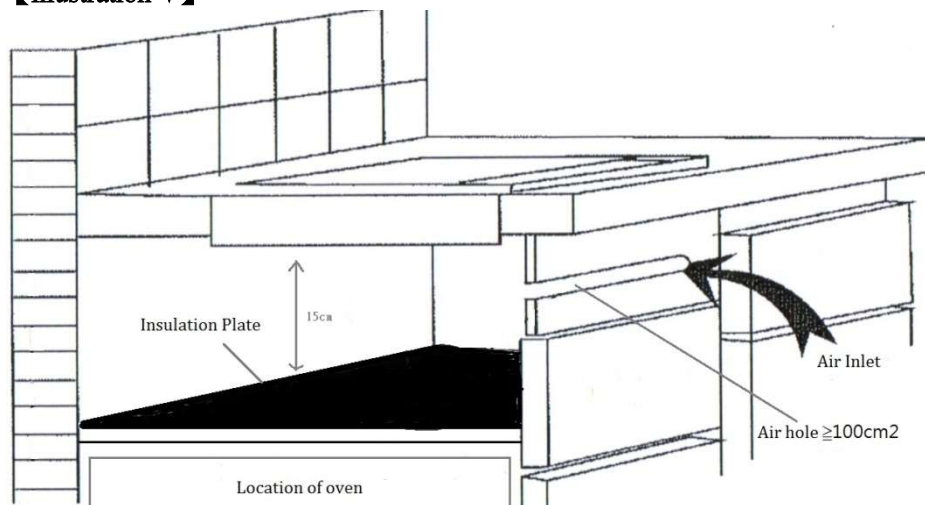

3、Control Panel Instruction

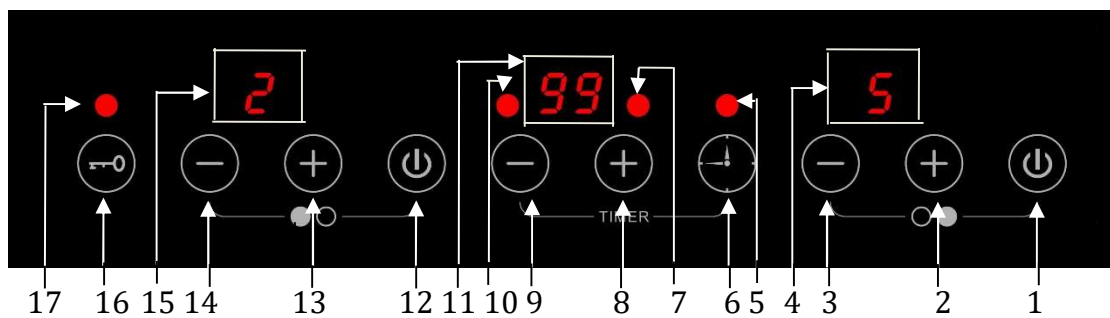
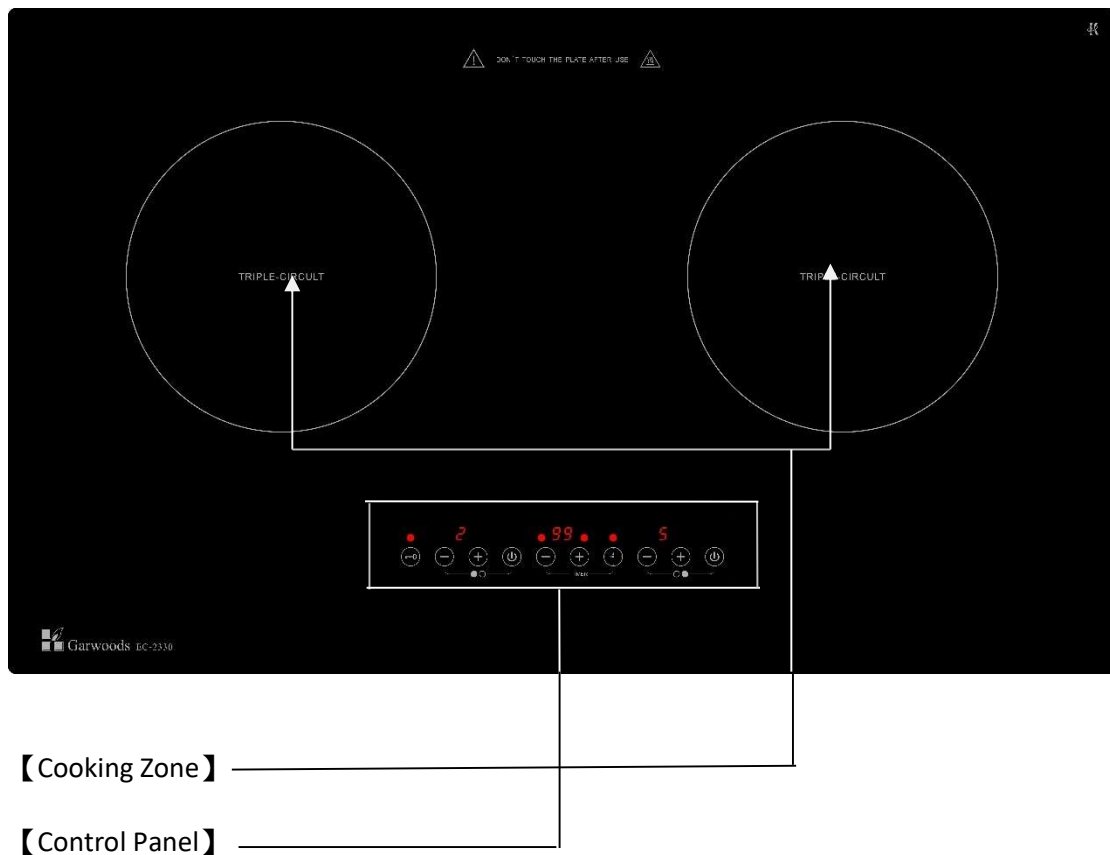

- | | |
|---|---|
| 1...On/Off (Right Zone) | 2...Power Plus Key (Right Zone) |
| 3...Power Minus Key (Right Zone) | 4...LED Digital Indicator (Power/High Temperature - Right Zone) |
| 5...Timer On/Off Indicator | 6...Timer Key |
| 7...Timer Indicator (Right Zone) | 8...Timer Plus Key |
| 9...Timer Minus Key | 10...Timer Indicator (Left Zone) |
| 11...LED Digital Indicator (Timer) | 12...On/Off (Left Zone) |
| 13...Power Plus Key (Left Zone) | 14...Power Minus Key (Left Zone) |
| 15...LED Digital Indicator (Power/High Temperature - Left Zone) | 16...Lock Key |
| 17...Lock Indicator | |

4 、 Operation Method

4.1 、 Operation Instructions :

- **Power Connection** : After power connection, buzzer will make a short sound. LED Digital Indicator will show [-] and the cooker keeps at the stand-by mode.
- **On switching** : Place cookware on heating zone (Pls. refer to Usable and Non-usable Cookware), by pressing the "ON/OFF" key, LED will show the pre-set power level "4".
- **Power Level Alteration** : At the power function, by pressing "+" Or "-" key to increase or decrease power level. LED digit shows set power level.

(Note : This infrared cooker adopts intellectual power distribution technology. When the power level of a cooker zone is increased and total power level exceeds specified value, the micro-computer system will automatically decrease power level of another cooker zone so as to assure total power is under specified value.)

- **Selecting Timer** : By pressing "Timer" key, the time indicator will be on. At the time, by pressing "+" Or "-" key to set the required time. The operational setting range is between 1 min. and 99 min. (Display form in 《mins》). When set time is reached, buzzer will make a long sound and the infrared cooker stops heating, the time indicator will be off. To cancel time setting, set the timing to "ZERO".

- **Lock Function** : By pressing the "Lock" key, buzzer will make a short sound and a red dot will be on. At this time, all keys will be locked in order to avoid mis-operation. By pressing "Lock" key again, buzzer will make a short sound and a red dot will be off.

The infrared cooker will be locked automatically after 15 seconds when switching off. For restarting the infrared cooker, by pressing the "Lock" key again, buzzer will make a short sound and the red dot will be off, then by pressing the "ON/OFF" key to enter the normal cooking mode by other function keys.

- **High Temperature Indicator** : When using infrared cooker after cooking, the LED digit will show "H" , that means the temperature on the heating zone is over 70°C. At this time, the heating zone is under a very high temperature condition, please do not attempt to place any combustible materials on the heating zone and touch the heating zone to avoid any risk of fire and getting burnt until the "H" in the LED Digital Indicator is vanished.
- **Off Switching** : During heating, by pressing "ON/OFF" key to switch off.

4.2 、 Usable and Non-usable Cookware :

1. Most of materials for a flat bottom cookware are suitable for use of the infrared cooker, such as stainless steel pot, iron pot, aluminum pot, ceramic pot and glass pot etc. The diameter of the flat bottom cookware is within 12-24 cm. For a good effect, it is recommended for an around 22 cm in diameter and depends on the thickness of the cookware at the flat bottom.
2. It is normal that feeling hot from the heating zone if the flat bottom cookware does not cover the circle on the heating zone because it will release far infrared rays when cooking.
3. The cookware is placed in the center of the circle at the heating zone.

4.3 、 Heating Power Distribution :

When two single zones are operating in the same time, the total power is up to 2800W. However, the power of one single zone will reduce automatically when the other zone is being cooking so as to maintain the total power level will not exceed 2800W.

Level	Power (W)
0/H	Stop power output
1	400
2	800
3	1100
4 (Pre-set level)	1400
5	1700
6	2000
7	2300

5 、 Safety Precautions

5.1 Safety Notes :

- No other objects than cookware to be placed on the calefaction area.
- Do not insert any objects like iron wire etc. into the vent in order to prevent any electric shock.
- Do not put anything to block the air outlet ◦
- Do not heat up unopened tins of food on the heating zone as pressure will build up in the tin and it can explode, which in turn could result in injury and scalding or damage.
- Do not use the infrared cooker in a high temperature environment. Keep it far away from fire.
- Always keep children away from the infrared cooker.
- Keep a distance between the water supply and the infrared cooker, to prevent any electric shock and interference or malfunction on function of the infrared cooker.
- Water or lliquid on the control panel will affect interference or malfunction on function of the infrared cooker.

5.2 、 Warning :

- The infrared cooker must not be installed over any metal work top or electrical appliances such as dishwasher, oven, and fridge etc.
- Do not place metallic objects such as knives, forks, scoops or spoons on the infrared cooker, calefaction area in order to prevent any danger caused by high temperature
- The plate of the infrared cooker is hot after cooking; do not touch the heating area by hand until the high temperature indictor is off or the glass surface has cooled down.
- If power wire is broken, you must shut off the power supply immediately and contact our After Sales Service professional to change the broken wire. User does not allow repairing by yourself, otherwise the maintenance of the infrared cooker will be invalid.
- Do not smash the glass surface, switch off the infrared cooker when the glass surface is cracked.

6 、 Daily Maintenance

- Clean the infrared cooker only when it has cooled down.
- Do not put any tinder of acid or alkaline materials near the infrared cooker in order to avoid the electric circuits inside the stove from the erosive damages of acidity and alkali which can affect the life span of the infrared cooker.
- Never use a steam cleaner or aggressive or abrasive detergent to clean the infrared cooker.
- Do not swash the infrared cooker directly with water.
- When cleaning the ceramic surface, wipe all coarse soiling off using a damp soft cloth and apply a few drops of proprietary-cleaning agent for ceramic surfaces.
- Do not let the bottom of the infrared cooker rubs the glass surface of the working area so as to prevent lacerating. (The laceration of the glass surface of the working area does not affect the normal operation of the infrared cooker).
- The air inlet should be cleaned regularly in order to have a good ventilation condition.
- Be sure to remove stains from the bottom of cookware. Otherwise, the stains will be scorched and stuck on the top plate.

7 、 Product Specification

Description	Intelligent Two-zone Infrared cooker
Model	EC-2330
Power Supply	AC220V/50Hz
Total Rated Power	2800W
Overall Dimension (W x D x H)	750 x 450 x 65 mm
Net Weight	10 Kg

8 、 Trouble-shooting Guideline

8.1 、 Code Of Breakdown :

In case of improper installation or use, abnormal power supply or breakdown of the infrared cooker, the LED digit on front panel will display code of breakdown.

Code of breakdown	Root cause of breakdown
E5	High power voltage
E6	Low Power voltage

8.2 、 Trouble Shooting :

Garwoods's infrared cooker has adopted the most advanced micro-computer inspection and control technology. Some phenomena appeared in the course of working may not indicate problems to occur.

Please check the infrared cooker according to the follow specifications :

Situation	Reason	Solution
No power for the light indicators	The power cord may not be properly connected to power outlet	Check the power cord if it has been connected or not
Auto-power off during working of product	<ol style="list-style-type: none">1. The inlet of fan is off.2. The fan stops working.3. The surrounding temperature is too high. Pls. check if there is some heating device nearby.4. The temperature of the stuff being heated rises too high.5. Errors of timer setting	<ol style="list-style-type: none">1. Clean and remove the stuff in the inlet of fan.2. Ask help from a professional service technician.3. Improve the ventilation.4. Improve the ventilation.5. Power off and re-start the product

目錄

一、產品簡介-----	13
I. 產品介紹	
II. 性能特點	
二、產品安裝說明-----	14-16
三、控制面板說明-----	17
四、產品操作說明-----	18-19
I. 操作說明	
II. 鍋具的選擇與使用	
III. 火力功率及功率分配說明	
五、使用注意事項-----	20
I. 安全注意事項	
II. 警告	
六、日常保養注意事項-----	21
七、產品規格-----	21
八、維修指南-----	22
I. 錯誤代碼	
II. 簡易故障的判別和排除	

一、產品簡介

I、產品介紹

多謝選購Garwoods EC智能雙頭電陶爐。本產品採用先進德國EGO核心發熱爐盤，內置S型發熱絲而釋放紅外線作加熱方式，數秒內可產生高溫達500-600°C的熱量，微電腦控制，輕觸式操作，安全耐用。適合各種不同的烹飪需求，是現代家庭廚房的理想之選。請在安裝及使用本產品之前閱讀本說明書。

II、性能特點

-
- **節能效益：** 本產品採用全新紅外線加熱原理，高熱效率，節能環保。在使用烹調食物過程中，更可因應情況下截斷電源利用爐面產生餘下的高溫而作短暫烹煮，以達到節省燃料之效果
- **齊全功能：** 採用最新微電腦晶片程式操作，具有多段火力功率調節，定時操控，自動調溫，餘溫警告指示等功能，方便實用。
- **環保安全：** 本產品在設計上充分考慮使用者的安全及環境保護。爐設有安全功能，如安全鎖、餘溫警告指示燈、2小時靜止操作及自動調溫功能等。
- **容易清潔：** 高級耐熱微晶玻璃面板、易潔耐用。烹調後，待餘溫警告指示熄滅及玻璃面板冷卻，才可進行清潔。
【注意：使用電陶烹煮後，面板仍處於高溫狀態，請勿放置任何易燃物件或接觸面板，以免造成火災及燙傷。】
- **輕觸式操作：** 輕觸式設計，只需要用手指輕輕觸摸玻璃控制面板上功能鍵即可，簡便易用。
- **智能功率：** 本產品採用智能功率分配技術。由微電腦根據用戶使用狀況，將規定的總功率分配到每個爐頭。

二、產品安裝說明

★安裝須遵守以下說明要求：

- 1、 工作枱面及靠近電陶爐的牆壁必須是耐熱的。
- 2、 用於安裝電陶爐與廚櫃的層板和膠黏劑必須是耐熱的。
- 3、 在任何安裝方式中，應確保爐具底下及爐面後側能徹底散熱，以確保安全。
- 4、 按規定尺寸在枱面上開一個安裝孔，同時確保任何一面距牆面距離至少100mm。
- 5、 安裝孔防水保護：若與濕氣接觸，製作廚櫃所用的層板相對容易膨脹，在開口邊緣塗上透明漆或專用膠黏劑，可防止水氣滲入造成蒸氣在廚櫃枱面下產生冷凝。
- 6、 在各種安裝條件下，電陶爐都需要良好的通風，要確保進氣口和出氣口不會被堵塞。
- 7、 電陶爐爐面四周及爐面垂直上方30cm的範圍內不要設置其它設備。
- 8、 如選擇座檯式安裝時，亦須確保排風口距離牆壁至少100mm。
- 9、 使用此型號電陶爐時必須配備**13**安培獨立開關掣或固定接線座。

★安裝步驟

1. 在需安裝電陶爐的廚櫃枱上按照【安裝圖 一】尺寸開一安裝孔
（注意：高度距離枱面需超過100mm）。

開孔尺寸(單位/mm)：(闊) 670 x (深) 350 x (高) 100

【安裝圖 一】

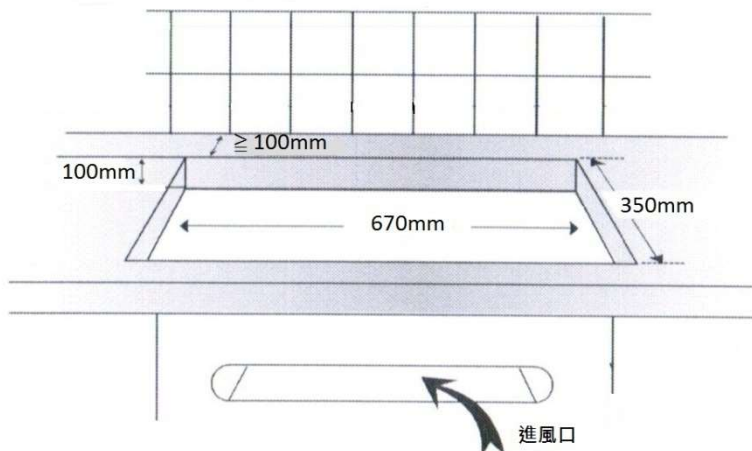

2. 在櫥櫃前側電陶爐放位置的下方開出一個大於 100cm^2 的進風口如【安裝圖二】，以確保電陶爐有足夠的散熱，如果櫥櫃不是密封式的，可以不開此口，但電陶爐下方不可有任何雜物堵塞通風。

【安裝圖 二】

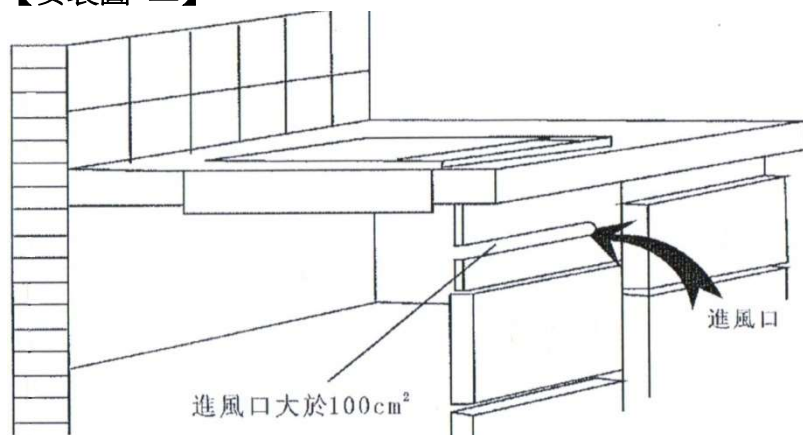

3. 安裝電陶爐在櫥櫃枱面前，必須將隨爐具所附的防水膠條如【安裝圖三】，貼在面板下方的四邊。如原枱面開孔大於本電陶爐開孔尺寸，應使用雙面貼貼在底盤四邊，以固定爐具與枱面而避免產生移動。

【安裝圖 三】

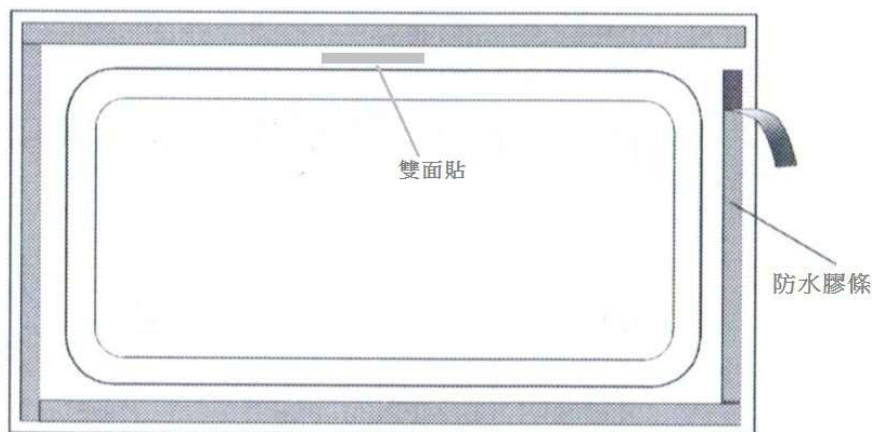

4. 將貼好防水膠條的電陶爐放入枱面開孔中如【安裝圖 四】，然後將電源線插頭插入對應的插座中，通電即可正常使用。

【安裝圖 四】

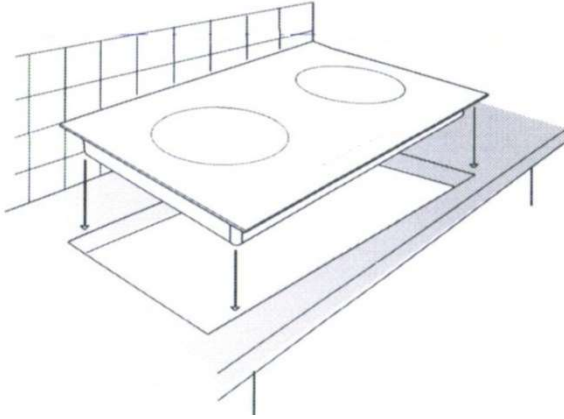

5. 如安裝電陶爐在烤箱上方時，櫥櫃內電陶爐與烤箱中必須加裝一個隔熱板如【安裝圖 五】隔熱板與電陶爐底部至少有15cm的距離；電陶爐安裝位置的前側必須開出一個大於100cm²的進風口以確保電陶爐陶與烤箱能夠有足夠的通風。

【安裝圖 五】

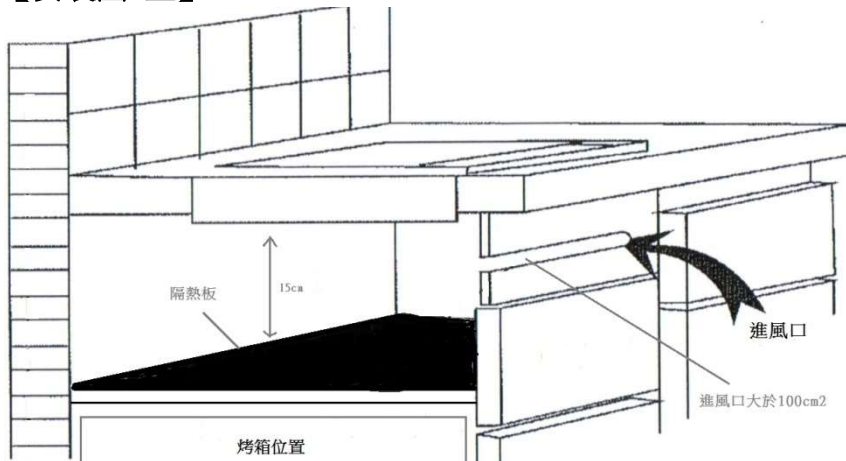

三、控制面板說明

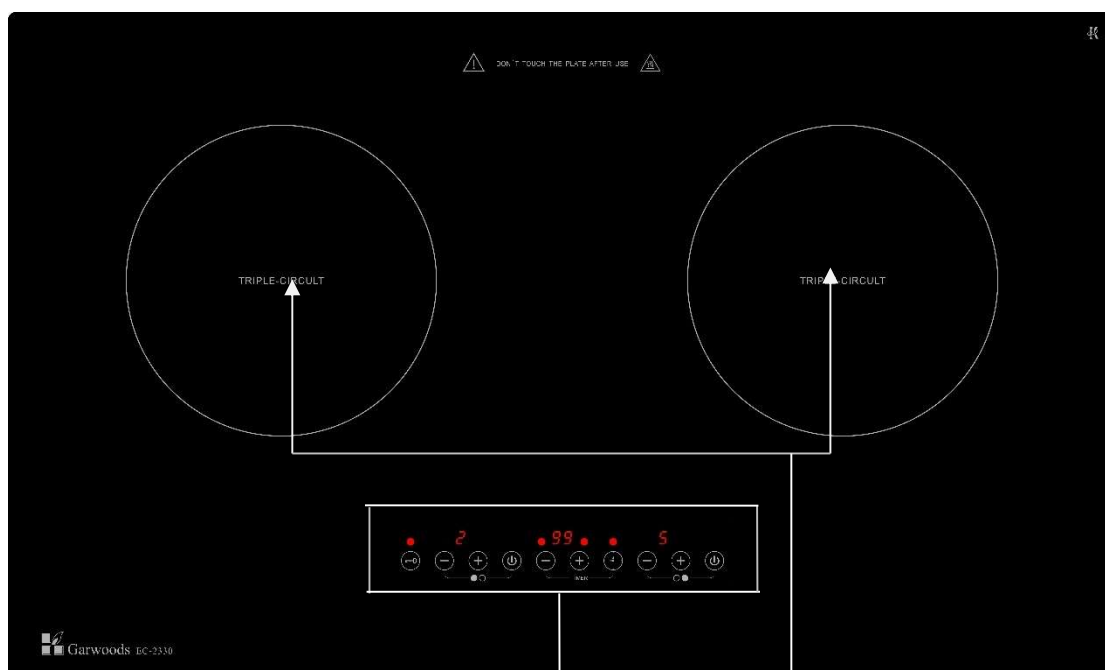

【加熱區】

【功能鍵】

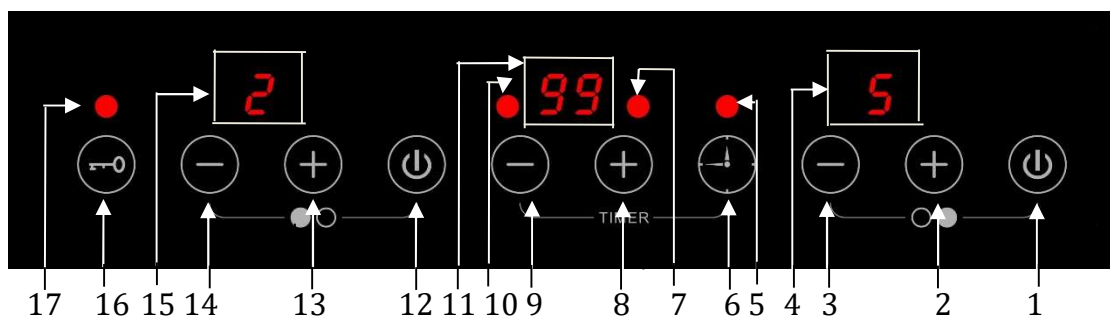

1...開關鍵(右方爐區)

3...火力調低鍵(右方爐區)

5...定時開關指示燈

7...定時指示燈(右方爐區)

9...定時調低鍵

11...LED數碼顯示區(定時)

13...火力調高鍵(左方爐區)

15...LED數碼顯示區

(火力及高溫指示 - 左方爐區)

17...安全鎖指示燈

2...火力調高鍵(右方爐區)

4...LED數碼顯示區

(火力及高溫指示 - 右方爐區)

6...定時鍵

8...定時調高鍵

10...定時指示燈(左方爐區)

12...開關鍵(左方爐區)

14...火力調低鍵(左方爐區)

16...安全鎖鍵

四、產品操作說明

I、操作說明：

- **通電：** 電源接通後，蜂鳴器會發出一短聲，表示電源已接通，LED數碼顯示會顯示〔-〕，電陶爐處於待機狀態。
- **開機：** 在加熱區放置所需的鍋具(請參考鍋具的選擇和使用)，按住“開關鍵”，LED數碼顯示會顯示預設檔為火力段數“4”。
- **調整火力：** 當火力功能運作時，按“調高鍵”或“調低鍵”可增大或減小火力功率，而LED數碼顯示區亦顯示所設定的火力段數。

(注意：本電陶爐採用智能功率分配技術，當增加某一爐頭火力功率時，在總功率超過額定功率的狀況下，系統會自動降低另一爐頭的火力功率，以確保功率不會超過額定功率值)

- **設置定時：** 按“定時鍵”，定時指示燈會亮，然後按“調高鍵”或“調低鍵”置定所需要的定時時間。此時LED數碼顯示區內會顯示設定時間(顯示格式為《分鐘》)，時間設定範圍為1分鐘至99分。設定完成後，LED數碼顯示即自動顯示回火力功率。當達到所設定的時間時，蜂鳴器會發出一長聲，電陶爐會停止加熱，定時指示燈會熄。若要取消定時設定，需要將定時時間設為0。
- **鎖定：** 按住“鎖定鍵”，蜂鳴器會發出一短聲，同時鎖定指示燈會亮着，此時鎖定功能啟動，其它按鍵將會被鎖定而無法操作以防止兒童觸碰或其他意外觸碰操作。若取消鎖定功能，再次按住“鎖定鍵”，蜂鳴器發出一短聲，鎖定指示燈熄滅，鎖定狀態被解除。

在關機狀態後15秒，電陶爐會自動上鎖，所有按鍵都不能操作。若需開啟電陶爐，先按“鎖定鍵”，蜂鳴器會發出一短聲，鎖定指示燈熄滅，鎖定狀態被解除，然後按“開關鍵”，其他按鍵才可使用。

- **餘溫警告指示：** 使用電陶爐烹煮後，LED數碼顯示區會顯示“H”，即表示加熱區爐面面板溫度達70°C，切勿放置任何易燃物件或接觸面板，以免造成火災及燙傷。待爐面面板溫度降至70°C以下，LED數碼顯示區顯示“H”會消失。
- **關機：** 加熱過程中，按“開關鍵”即可關機。

II、鍋具的選擇與使用：

1. 電陶爐適用於各種材質的平底鍋具，包括不銹鋼、鐵、鋁、銅、耐熱玻璃、陶瓷及紫砂鍋等。而底部直徑必須在12-24厘米範圍內。若要達到最佳烹調效果，建議鍋具底部直徑於22厘米左右及底部厚度不要太厚。
2. 在煮食過程中，因電陶爐加熱區會釋放紅外線而產生高熱效率，若鍋具底部直徑未能覆蓋加熱區，將會感受有些熱力，這情況下是屬於正常現象。
3. 鍋具需放置在面板上加熱區的中央位置內。

III、火力功率分配說明：

當兩邊爐頭同一時間運作時，兩邊火力功率之和最高為2800瓦，當一邊火力功率增大，另一邊火力功率將自動下調，以保持火力功率之和不超過2800瓦。

火力段數	火力功率(瓦)
0/H	停止火力輸出
1	400
2	800
3	1100
4 (預設檔)	1400
5	1700
6	2000
7	2300

五、使用注意事項

I、安全注意事項

- 電陶爐上不要放置除加熱鍋具外的任何物體。
- 排氣口與吸氣口請勿插入鐵絲等異物，以避免發生觸電危險。
- 切勿堵塞排氣口。
- 請勿加熱沒有開封的罐頭類產品，因氣壓內積聚並會引起爆炸；導致身體受損或傷害。
- 請勿將爐具擺放在高溫環境中使用，並且這遠離火源。
- 時刻讓小朋友遠離電陶爐。
- 水源與電陶爐必須保持距離，以避免發生觸電危險及水份滲入電陶爐而產生功能上的干擾或故障。
- 水或類似液體留在電陶爐控制區域或附近表面，會令電陶爐產生功能上的干擾或故障。

II、警告

- 禁止將電陶爐擺放在鐵製檯面或家用電器上工作（如鐵製廚櫃、消毒碗櫃、雪櫃、焗爐、洗碗碟機等）。
- 爐具工作時請勿將金屬物件，如刀、叉、勺、蓋等物件放在上面，防止被意外加熱。
- 爐具使用後，因受加熱鍋具高溫影響，加熱區留有餘溫頗高，當餘溫警告指示燈會亮着，即表示加熱區爐面面板溫度達60°C時，切勿放置任何易燃物件或接觸面板，直至玻璃面板冷卻，以免造成火災及燙傷。
- 電陶爐出現異常情況，如電源線破損等，須由代理商或被授權的維修專業人員進行更換維修。用戶不得自行更換拆卸，否則不予保修（如產生任何安全事故，本公司概不負責）。
- 如陶瓷玻璃面板破裂，請立即關機，拔掉電源插頭以防觸電。須由代理商或被授權的維修專業人員進行更換維修。

六、日常保養注意事項

- 清洗電陶爐玻璃面板前，電陶爐玻璃面板應先完全冷卻。
- 爐具周圍請勿放置任何易燃、酸性或鹼性物品，以免酸、鹼對電陶爐中的電路板受腐蝕而影響電陶爐的壽命。
- 禁止使用蒸汽、腐蝕性或磨砂的清潔劑來清洗電陶爐。
- 請勿用水直接沖洗機體。
- 陶瓷玻璃面板的清潔：陶瓷玻璃面板髒污的時候，用布沾水輕輕擦拭，如擦不掉時用稀釋中性去污粉或清潔劑清潔後，再用濕布擦拭即可。
- 請勿用有機溶劑或含苯等化學藥品擦拭電陶爐，以免產生化學作用。切勿使用硬刷子刷洗爐面，使用鍋具底部時不要摩擦工作區的陶瓷玻璃面板表面，以免造成面板刮傷（工作區陶瓷玻璃面板表面刮傷不影響電陶爐的使用）。
- 定期清理進風口污漬與灰塵。
- 請確保移除器皿底部污漬。否則，污漬會燒焦後附在面板上。

七、產品規格

產品	智能雙頭電陶爐
型號	EC-2330
適用電源	AC220伏特/50赫茲
總輸出火力功率	2800瓦
爐身尺寸(闊 x 深 x 高)	750 x 450 x 65毫米
淨重量	10千克

八、維修指南

I、錯誤代碼

當電陶爐安裝或使用不當、供電不正常或電陶爐出現故障時，面板上的LED數碼顯示燈將顯示錯誤代碼。

錯誤代碼	錯誤原因
E5	供電電壓過高
E6	供電電壓過低

II、簡易故障的判別和排除

由於本機採用了最先進的微電腦檢測控制技術，所以在爐具工作中出現的一些現象並不意味有故障，請先按以下說明檢查。

現象	可能原因	解決方式
指示燈不着	電源未正確地接駁或接觸不良	驗查電源插頭是否已正確地接駁電源插座及是否有鬆脫情況
自動停機	<ol style="list-style-type: none">1. 風扇進風口被塞堵。2. 風扇停轉3. 安裝使用環境溫度過高4. 散熱位置被堵塞5. 定時設定錯誤	<ol style="list-style-type: none">1. 清潔、去除進風口堵塞物2. 由專業維修人員修理3. 改善環境條件4. 改善環境條件5. 關機及重新設定

Sole Agent : Araytron Technology Limited
總代理 : 千中科技有限公司
Enquiry/查詢熱線 : + 852 2397 3066 Fax/傳真 : + 852 2397 3055
Website/網址 : www.garwoods.com.hk