



Two-Zone Induction Cooker
雙頭電磁爐

Model/型號：S8-2928IC

Installation & Operating Instructions
產品使用說明書

CONTENTS

1 、 Product Introduction-----	2
1.1 .Introduction of Product	
1.2 .Function & Characteristics	
2 、 Installation Guideline-----	3-5
3 、 Control Panel Instructions-----	6
4 、 Operation Method-----	7-9
4.1 .Operation Instructions	
4.2 .Usable and Non-usable Cookware	
4.3. Heating Power Distribution	
4.4 Caution	
5 、 Safety Precautions-----	9-10
5.1 .Safety Notes	
5.2 .Warning	
6 、 Daily Maintenance-----	10
7 、 Product Specification-----	11
8 、 Trouble-Shooting Guideline-----	11-12
8.1 .Code Of Breakdown	
8.2 .Trouble Shooting	

1 、 Product Introduction

1.1 、 Introduction Of Product :

Thank you for choosing **Garwoods Induction Cooker**. This product utilizes electromagnetic heating theory and be controlled by the micro-computer touching sensor control system. There are multi-functions which cater for any delicious cuisine. It is an ideal product for modern family. Please read this operation manual carefully before installing or using this product.

1.2 、 Function & Characteristics :

- **Energy-efficient** : It utilizes the brand-new calefaction principle. The thermal efficiency is extremely high. It is both time-saving & energy-saving. Calefaction begins when a boiler is on and heating is stopped when the boiler is removed.
- **Multi-function** : It utilizes newest micro-computer chip program control. It offers multiple scales for heating power level regulation. Also, it offers timing regulation and can automatically check whether there is cooker on or not.
- **Safety & Environmental Friendly** : Safety & Environmental Friendly of the product is on our top priority. **1)** Only cookware with a ferromagnetic material would be heated; **2)** If the body temperature of cookware is too high or the voltage change causes too strong electric current, the cooker will enter into a self-protection system; **3)** Automatic shut off by entering into a self-protection system after 2 hours not in use during cooking; **4)** The surface of the cooker is a high quality heat-resistant ceramic glass that is insulated and guarded from leakage; **5)** No need to worry about bringing possible damage to the cooker when overflowing of soup; **6)** The cooker is free from typical problems such as leakage, explosion, flaming burns etc. The chance of accidents are greatly reduced; **7)** Fireless and smokeless cooking is easier made for any cuisine. Meanwhile, it will keep your family members out of respiratory system allergy.
- **Easy-to-clean Surface** : Ceramic glass top panel is easy to clean. Wipe it with a damp cloth after cooking.
- **Touch Buttons Operation** : Touch button design is easy for use.
- **Intellectual Power** : The induction cooker adopts intellectual power distribution technology and the specified power can be distributed to each cooker zone by the micro-computer system.

2、Installation Guideline

★ Installation should be followed below requirements：

- 1、The walls on top of the working face and next to the installation of induction cooker must be heat-proof.
- 2、The laminated boards and adhesive used for installation must be heat-resistant.
- 3、For any installation method, the air under the cooker and behind the cooking range should have enough space for cooling in order to ensure the safety of operating the induction cooker.
- 4、Based on the prescribed dimensions, a square hole is opened on the work table. Ensure the distance between any side of the work table and the walls is $\geq 100\text{mm}$.
- 5、Protect the opening: If in contact with damp, the laminated boards used in marking the work table will easily expand more. It is required to stick varnish or special adhesive onto the edge of the opening in order to prevent any steam from condensation under the work table.
- 6、For any condition of installation, the induction cooker should have a good ventilation condition with air inlet and air outlet not blocked.
- 7、Don't place other equipments on the working face of the double cooking zones of the induction cooker and within the range of 30cm around the working face.
- 8、If choosing a table-top installation, ventilation hole shall be at least 100mm from wall surface.
- 9、The induction cooker must be complied with a 13A power outlet.

★ Steps on Installation：

~ Open an installation hole on the worktop of cabinet as per **【illustration 1】**.
(Note：The height shall be more than 100mm)

Cut out dimensions(unit/mm)：(W) 670 x (D) 350 x (H) 100

【illustration 1】

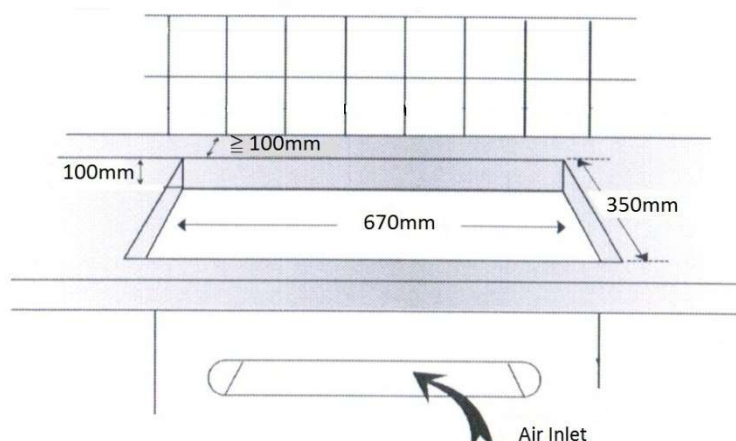

* If the installation hole on the work table is a new open, it is recommended a depth to 370mm and put the cooker into the hole at front side so as to have a good ventilation condition.

~ In front of the cabinet, open an air inlet with more than 100cm² under the location of induction cooker as per 【illustration II】 . If the cabinet is not sealed, the air inlet may not be opened so as to ensure heat elimination.

【illustration II】

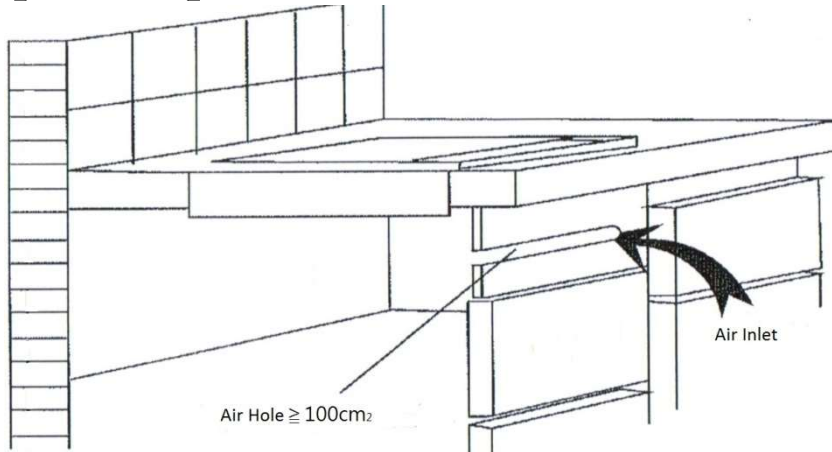

~ Before put the induction cooker into the hole, an water-proof type is properly applied on the bottom of front panel of the induction cooker as per 【illustration III】 . If the old size of the hole is large than the current size of cutting hole, a double side type can be used to fix the movement between induction cooker and worktop.

【illustration III】

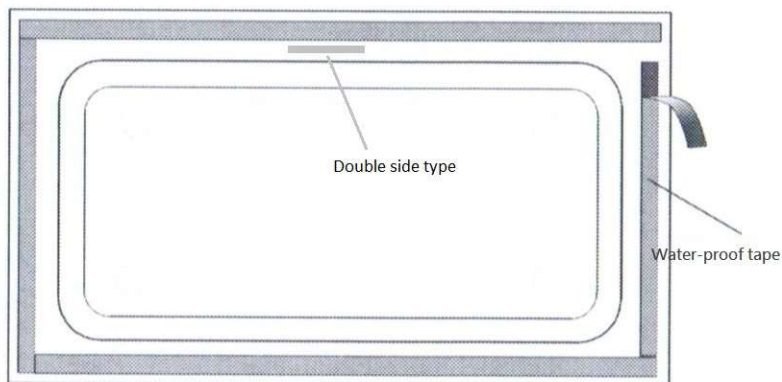

~ Put induction cooker into hole. Insert plug of power line into corresponding socket. The induction cooker can be used after power connection as per 【illustration IV】 .

【illustration IV】

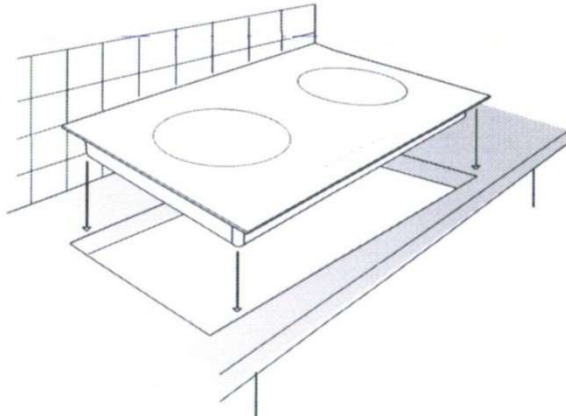

~ If the induction cooker is installed above an oven, fix an insulation part at least 15cm under the induction cooker as per 【illustration V】 . Also, open an air inlet with more than 100cm² under the location of the induction cooker to ensure ventilation and operation in good conditions

【illustration V】

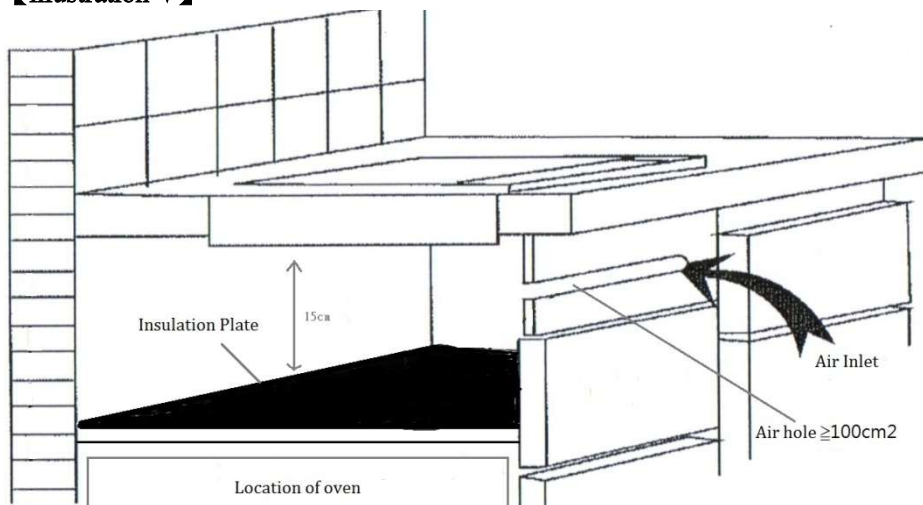

3、Control Panel Instruction

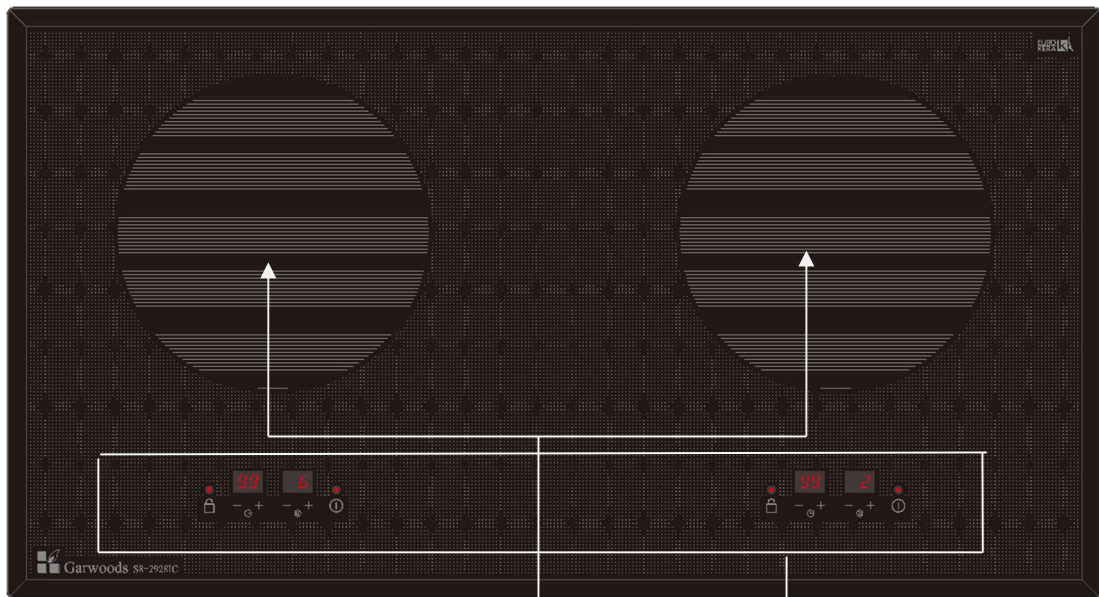

【Cooking Zone】

【Control Panel】

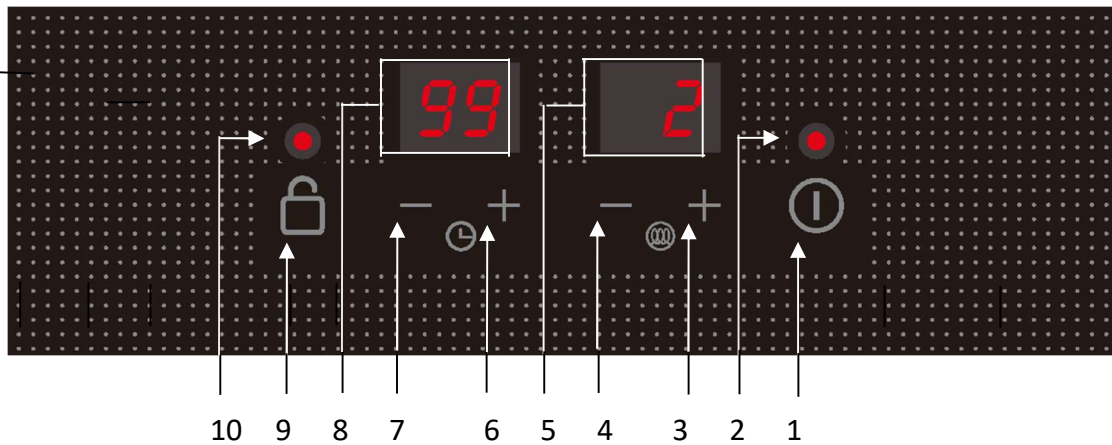

- 1...On/Off Switch
- 3...Plus Key (Power)
- 5...LED Digital Indicator (Power)
- 7...Minus Key (Timer)
- 9...Lock Key

- 2...On/Off Indicator
- 4...Minus Key (Power)
- 6...Plus Key (Timer)
- 8...LED Digital Indicator (Timer)
- 10...Lock Indicator

4 、 Operation Method

4.1 、 Operation Instructions :

- **Power Connection** : After power connection, buzzer will make a short sound and the induction cooker keeps at the stand-by mode. LED digit indicator (Power) will show “- -”. If no working of the induction cooker after 15 sec., the induction cooker will automatically be locked
- **On switching** : Place cookware on heating zone (Pls. refer to Usable and Non-usable Cookware), by pressing the “ON/OFF” key, buzzer will make a short sound and the on/off indicator will be on. By pressing “+” Or “-” key (Power) . LED digit indicator (Power) will show the pre-set power level “4”.
- **Power Level Alteration** : At the power function, by pressing “+” Or “-” key (Power) to increase or decrease the power level. LED digit indicator (Power) shows set power level.

(Note : This induction cooker adopts intellectual power distribution technology. When the power level of a cooking zone is increased and total power level exceeds specified value, the micro-computer system will automatically decrease power level of another cooking zone so as to assure total power is under specified value.)

- **Selecting Timer** : By pressing “+” Or “-” key (Timer) to set the required time. The operational setting range is between 1 min. and 99 min. (Display form in 《mins》). After setting, the LED digit indicator (Timer) will show the required time. When set time is reached, buzzer will make a long sound and the induction cooker stops heating. To cancel time setting, by pressing “-” key to set the time to zero.
- **Lock Function** : By pressing the “Lock” key, buzzer will make a short sound and a red dot will be on. At this time, all keys will be locked in order to avoid mis-operation. By pressing “Lock” key 3 sec. again, buzzer will make a short sound and a red dot will be off.

The induction cooker will be locked automatically after 15 sec. when switching off. For restarting the induction cooker, by pressing the “Lock” key 3 sec. again, buzzer will make a short sound and the red dot will be off, then by pressing the “ON/OFF” key to enter the normal cooking mode by other function keys.

- **Off Switching** : During heating, by pressing “ON/OFF” key to switch off.

4.2 、 Usable and Non-usable Cookware :

~ Please refer to below information to select a suitable cookware cater for all delicious cuisine by the induction cooker.

Usable Cookware	Non-usable Cookware
【Materials】 Iron, cast iron, stainless steel and enamel cookware.	【Materials】 Cookware made of pottery, aluminum, glass, copper or bronze.
【Shape and size】 The diameter more than 120mm (4.5 inches) are recommended.	【Shape and size】 The bottom diameter of the cookware is less than 120mm (4.5 inches). And, the cookware with curved bottom, with concave bottom (the concave depth \geq 4mm) or with legs (the height \geq 4mm).
【Sorts of suitable cookware】 Stainless steel kettle, iron tray, bottom pan, iron pot, iron tray, enamel pot etc.	【Sorts of un-suitable cookware】 Copper, bronze and aluminum pot, glass pot, pottery pot, bronze pan etc.

~ Put the suitable cookware on the central position of the heating zone.

~ It is normal that sound “ze..ze..” from the cookware when heating.

4.3 、 Heating Power Distribution :

When two single zones are operating in the same time, the total power is up to 7. However, the power of one single zone will reduce automatically when the another zone is being cooking so as to maintain the total power level will not exceed 7.

Left Zone		Right Zone	
Level	Power(W)	Level	Power(W)
7	2800	0	0
6	2400	1	400
5	2000	2	800
4	1600	3	1200
3	1200	4	1600
2	800	5	2000
1	400	6	2400
0	0	7	2800

4.4 、 Caution :

- Don't place any metal cooking utensils, e.g. knife, fork, spoon, lid over the heating zone to avoid getting burnt.
- Don't place an empty cookware on the heating zone that will cause damage of the induction cooker.
- Beware of the cookware gets overheated and burnt while heating up oil.
- Please use level 3 for deep fry cooking. Otherwise, the induction cooker will turn off automatically after cooking around 20 minutes. And the LED indicator will show the "E2"

5 、 Safety Precautions

5.1 Safety Notes :

- No other objects then cookware to be placed on the calefaction area.
- Do not insert any objects like iron wire etc. into the vent in order to prevent any electric shock.
- Do not put anything to block the air outlet ◦
- Do not heat up unopened tins of food on the heating zone as pressure will build up in the tin and it can explode, which in turn could result in injury and scalding or damage.
- Do not use the induction cooker in a high temperature environment. Keep it far away from fire.
- Do not lay object, which are susceptible to the magnetic fields such as credit cards, diskettes in the immediate vicinity of the induction cooker.
- Always keep children away from the induction cooker and children should be supervised to ensure that they do not play with the appliance.
- Keep a distance between the water supply and the induction cooker, to prevent any electric shock and interference or malfunction on function of the induction cooker.
- Water or liquid on the control panel will affect interference or malfunction on function of the induction cooker.
- The appliances are not intended to be operated by means of an external timer or separate remote-control system.
- This appliance is not intended for use by persons (including children) with reduced physical, sensory or mental capabilities, or lack of experience and knowledge, unless they have been given supervision or instruction concerning use of the appliance by a person responsible for their safety.
- This appliance is intended to be used in household and similar applications such as:
 - Staff kitchen areas in shops, offices and other working environments;
 - Farm houses;
 - By clients in hotels, motels and other residential type environments;
 - Bed and breakfast type environments.

5.2 、 Warning :

- The induction cooker must not be installed over any metal work top or electrical appliances such as dishwasher, oven, and fridge etc.
- Do not place metallic objects such as knives, forks, scoops or spoons on the induction cooker, calefaction area in order to prevent any danger caused by high temperature
- The plate of the induction cooker is hot after cooking; do not touch the heating area by hand.
- If power wire is broken, you must shut off the power supply immediately and contact our After Sales Service professional to change the broken wire. User does not allow repairing by yourself, otherwise the maintenance of the induction cooker will be invalid.
- Do not smash the glass surface, switch off the induction cooker when the glass surface is cracked.

6 、 Daily Maintenance

- Clean the induction cooker only when it has cooled down.
- Do not put any tinder of acid or alkaline materials near the induction cooker in order to avoid the electric circuits inside the stove from the erosive damages of acidity and alkali which can affect the life span of the induction cooker.
- Never use a steam cleaner or aggressive or abrasive detergent to clean the induction cooker.
- Do not swash the induction cooker directly with water.
- When cleaning the ceramic surface, wipe all coarse soiling off using a damp soft cloth and apply a few drops of proprietary-cleaning agent for ceramic surfaces.
- Do not let the bottom of the induction cooker rubs the glass surface of the working area so as to prevent lacerating. (The laceration of the glass surface of the working area does not affect the normal operation of the induction cooker).
- The air inlet should be cleaned regularly in order to have a good ventilation condition.
- Be sure to remove stains from the bottom of cookware. Otherwise, the stains will be scorched and stuck on the top plate.

7、Product Specification

Description	Two-zone Induction Cooker
Model	S8-2928IC
Power Supply	AC220-240V/50Hz
Total Rated Power	2800W
Overall Dimension(W x D x H)	740 x 400 x 65 mm
Net Weight	10 Kg

8、Trouble-shooting Guideline

8.1、Code Of Breakdown：

In case of improper installation or use, abnormal power supply or breakdown of the induction cooker, the LED digit on front panel will display code of breakdown.

Code of breakdown	Root cause of breakdown
E0	Failure of Circuit
E1	Cookware not be sensed on the cooking zone
E2	High temperature inside induction heater
E3	Failure of heater temperature sensor
E4	Failure of IGBT temperature sensor
E5	High power voltage
E6	Low Power voltage

8.2 、 Trouble Shooting :

Garwoods induction cooker has adopted the most advanced micro-computer inspection and control technology. Some phenomena appeared in the course of working may not indicate problems to occur.

Please check the induction cooker according to the follow specifications :

Situation	Reason	Solution
The heater works for a while and stop, indicating "E1"	<ol style="list-style-type: none">1. No cook ware put on the cooking zone2. Non-usable cookware is used	<ol style="list-style-type: none">1. Put the cookware on the cooking zone2. Refer to "Usable and Non-usable cookware" in the operation manual
The heater works for a while and stops, indicating "E2" .	<ol style="list-style-type: none">1. The inlet of fan is off.2. The fan stops working.3. The surrounding temperature is too high. Pls. check if there is some heating device nearby.4. The temperature of the stuff being heated rises too high.	<ol style="list-style-type: none">1. Clean and remove the stuff in the inlet.2. Ask help from a professional service technician.3. Improve the ventilation.4. Remove the cause for fry heating and continue to use the cooker after the calefaction area is cooling down.
The heater works for a while and stop, indicating "E3" or "E4" .	The temperature sensor breakdown.	Ask help from a professional service technician.

目錄

一、產品簡介-----	14
I. 產品介紹	
II. 性能特點	
二、產品安裝說明-----	15-17
三、控制面板說明-----	18
四、產品操作說明-----	19-21
I. 操作說明	
II. 鍋具的選擇與使用	
III. 火力段數及功率分配說明	
IV. 警告事項	
五、使用注意事項-----	21-22
I. 安全注意事項	
II. 警告	
六、日常保養注意事項-----	22
七、產品規格-----	23
八、維修指南-----	23-24
I. 錯誤代碼	
II. 簡易故障的判別和排除	

一、產品簡介

I、產品介紹

多謝選購Garwoods 智能電磁爐。本產品採用先進電磁加熱方式，微電腦控制，輕觸式操作，安全耐用。適合各種不同的烹飪需求，是現代家庭廚房的理想之選。請在安裝及使用本產品之前閱讀本說明書。

II、性能特點

- **節能效益：** 本產品採用全新加熱原理，傳熱效率高，省時省電，鍋具放置電磁爐後開始加熱，取走鍋具後立即停止加熱。從而達到煮食節能目的。
- **齊全功能：** 採用最新微電腦晶片程式操作，具有多段火力段數調節，定時操控，自動鍋具檢測等功能，方便實用。
- **環保安全：** 本產品在設計上充分考慮使用者的安全及環境保護。**1)**加熱區只能感應適用電磁爐的鍋具；**2)**當鍋體溫度過高或電壓變動導致電流過大，本產品將自動進入保護狀態；**3)**使用過程中如無指令接收達到兩小時後，自動停機保護啟動；**4)**爐面選用高級耐熱微晶玻璃面板，絕緣防漏；**5)** 無需擔心湯水溢出燒壞電磁爐；**6)**無煤氣爐常見的洩漏、爆炸、明火灼傷等危險，減少意外事故的發生；**7)**烹調過程中無明火、無煙，令烹飪變得潔淨容易，令家居環境清新及家人健康。
- **容易清潔：** 高級耐熱微晶玻璃面板、易潔耐用。烹調後，只須用布輕輕一抹即可。
- **輕觸式操作：** 輕觸式觸控設計，只需要用手指輕輕觸摸玻璃控制面板上功能鍵即可，簡便易用。
- **智能功率：** 本產品採用智能功率分配技術。由微電腦根據用戶使用狀況，將規定的總功率分配到每個爐頭。

二、產品安裝說明

★安裝須遵守以下說明要求：

- 1、 工作枱面及靠近電磁爐的牆壁必須是耐熱的。
- 2、 用於安裝電磁爐與廚櫃的層板和膠黏劑必須是耐熱的。
- 3、 在任何安裝方式中，應確保爐具底下及爐面後側能徹底散熱，以確保安全。
- 4、 按規定尺寸在枱面上開一個安裝孔，同時確保任何一面距牆面距離至少100mm。
- 5、 安裝孔防水保護：若與濕氣接觸，製作廚櫃所用的層板相對容易膨脹，在開口邊緣塗上透明漆或專用膠黏劑，可防止水氣滲入造成蒸氣在廚櫃枱面下產生冷凝。
- 6、 在各種安裝條件下，電磁爐都需要良好的通風，要確保進氣口和出氣口不會被堵塞。
- 7、 電磁爐爐面四周及爐面垂直上方30cm的範圍內不要設置其它設備。
- 8、 如選擇座檯式安裝時，亦須確保排風口距離牆壁至少100mm。
- 9、 使用此型號電磁爐時必須配備**13**安培獨立開關掣或固定接線座。

★安裝步驟

1. 在需安裝電磁爐的廚櫃枱上按照【安裝圖 一】尺寸開一安裝孔
（注意：高度距離枱面需超過100mm）。

開孔尺寸(單位/mm)：(闊) 670 x (深) 350 x (高) 100

【安裝圖 一】

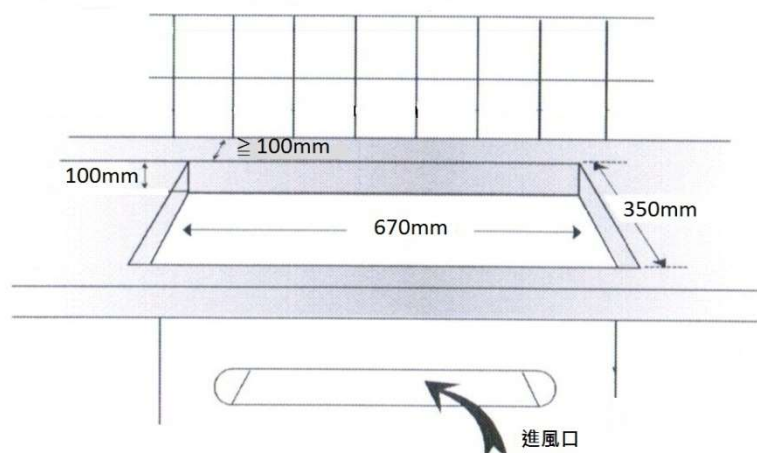

* 如屬新枱面開孔，開孔深度可開至 370 毫米，並將電磁爐緊貼枱面前方放進孔內以預留背部較多散熱空間

2. 在櫥櫃前側電磁爐放位置的下方開出一個大於 100cm^2 的進風口如【安裝圖二】，以確保電磁爐有足夠的散熱，如果櫥櫃不是密封式的，可以不開此口，但電磁爐下方不可有任何雜物堵塞通風。

【安裝圖 二】

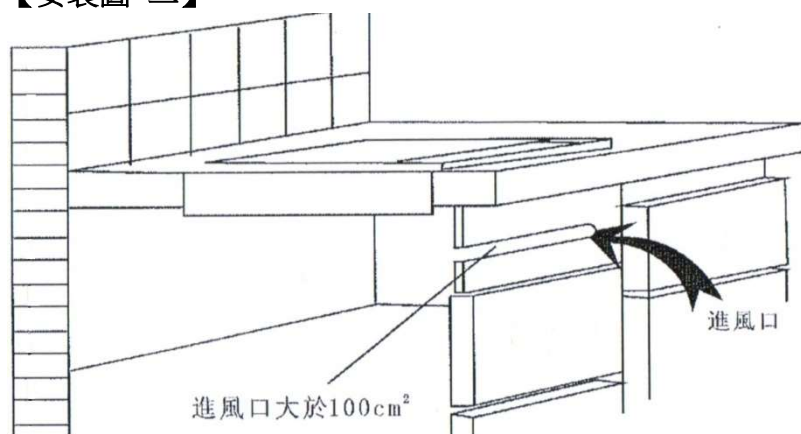

3. 安裝電磁爐在櫥櫃枱面前，必須將隨爐具所附的防水膠條如【安裝圖三】，貼在面板下方的四邊。如原枱面開孔大於本電磁爐開孔尺寸，應使用雙面貼貼在底盤四邊，以固定爐具與枱面而避免產生移動。

【安裝圖 三】

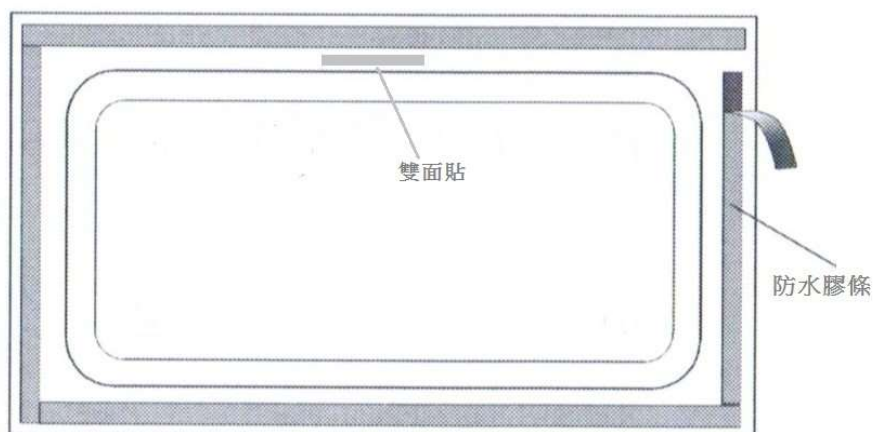

4. 將貼好防水膠條的電磁爐放入枱面開孔中如【安裝圖 四】，然後將電源線插頭插入對應的插座中，通電即可正常使用。

【安裝圖 四】

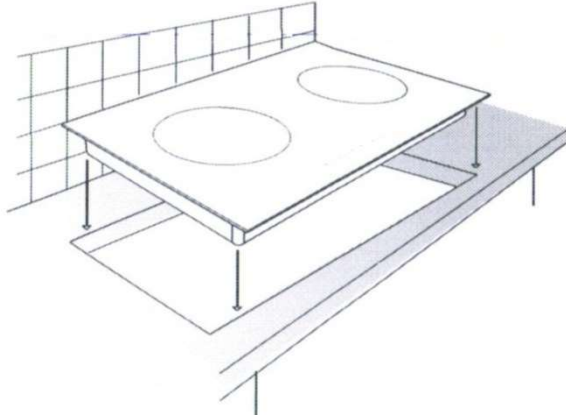

5. 如安裝電磁爐在烤箱上方時，櫥櫃內電磁爐與烤箱中必須加裝一個隔熱板如【安裝圖 五】隔熱板與電磁爐底部至少有15cm的距離；電磁爐安裝位置的前側必須開出一個大於100cm²的進風口以確保電磁爐與烤箱能夠有足夠的通風。

【安裝圖 五】

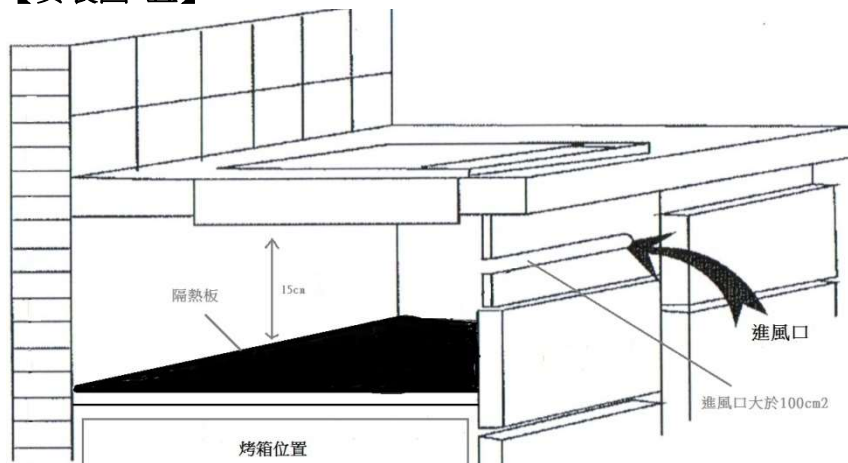

三、控制面板說明

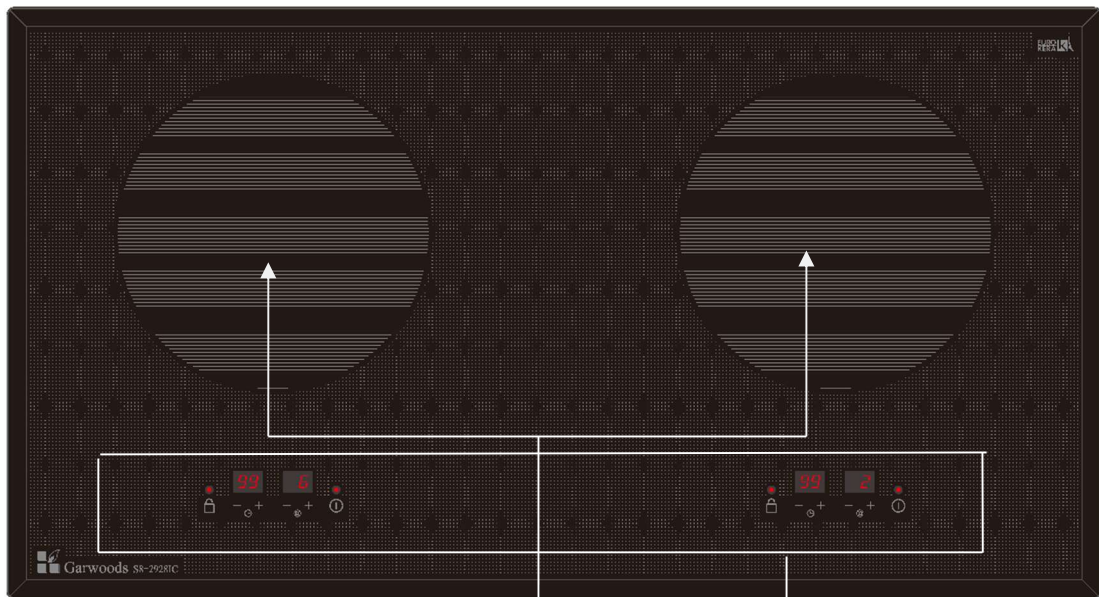

【加熱區】

【功能鍵】

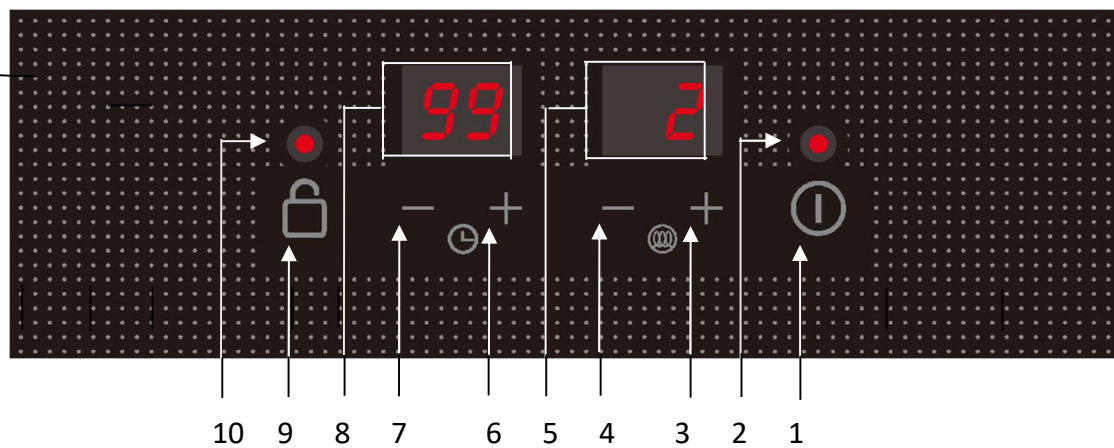

- 1…開關鍵
- 3…調高鍵 (火力)
- 5…LED數碼顯示區 (火力)
- 7…調低鍵 (定時)
- 9…安全鎖鍵

- 2…開關指示燈
- 4…調低鍵 (火力)
- 6…調高鍵 (定時)
- 8…LED數碼顯示區 (定時)
- 10…安全鎖指示燈

四、產品操作說明

I、操作說明：

- **通電：** 接通電源後，蜂鳴器會發出一短聲，表示電源已接通，電磁爐處於待機狀態，LED數碼顯示區 (火力) 內會顯示為 (- -) 。如通電後15秒沒有任何工作，電磁爐的鎖定功能將會自動啟動。
- **開機：** 在加熱區放置所需的鍋具(請參考鍋具的選擇和使用) ，按住“開關鍵”，蜂鳴器會發出一短聲，開關指示燈會亮，再按住“調高鍵”或“調低鍵” - (火力) ，LED數碼顯示區 (火力)會顯示為預設火力段數“4” 。
- **調整火力：** 當火力功能運作時，按“調高鍵”或“調低鍵” - (火力)可增大或減小火力段數，而LED數碼顯示區 (火力) 亦顯示所設定的火力段數。

(注意：本電磁爐採用智能功率分配技術，當增加某一爐頭火力段數時，在總功率超過額定功率的狀況下，系統會自動降低另一爐頭的火力段數，以確保功率不會超過額定功率值)
- **設置定時：** 按“調高鍵”或“調低鍵”(定時)置定所需要的定時時間。此時LED數碼顯示區 (定時)內會顯示設定時間 (顯示格式為《分鐘》) ，時間設定範圍為1至99分鐘。當達到所設定的時間時，蜂鳴器會發出一長聲，電磁爐會停止加熱。若要取消定時設定，只需按“調低鍵”(定時) 重置所設定的時間為“0” 。
- **鎖定：** 按住“鎖定鍵”，蜂鳴器會發出一短聲，同時鎖定指示燈會亮着，此時鎖定功能啟動，其它按鍵將會被鎖定而無法操作以防止兒童觸碰或其他意外觸碰操作。若取消鎖定功能，再次按住“鎖定鍵” 3秒，蜂鳴器發出一短聲，鎖定指示燈熄滅，鎖定狀態被解除。

在關機狀態後15秒，電磁爐會自動上鎖，所有按鍵都不能操作。若需開啟電磁爐，先按“鎖定鍵” 3秒，蜂鳴器會發出一短聲，鎖定指示燈熄滅，鎖定狀態被解除，然後按“開關鍵”，其他按鍵才可使用。
- **關機：** 加熱過程中，按“開關鍵”即可關機。

II、鍋具的選擇與使用：

1. 配合電磁爐煮食，應參考下列指引選擇與使用適合的鍋具。

適合的鍋具	不適合的鍋具
【物料】 鐵或導磁不鏽鋼底的鍋具，最好選用註明「適合電磁爐煮食」的鍋具。	【物料】 以非鐵金屬(如鋁、銅)、陶瓷、耐熱玻璃等物料為鍋底的鍋具。
【形狀】 底部直徑必須在12-26cm範圍的平底鍋，鍋具重量連同盛載食物每邊不可起過20kg。	【形狀】 底部凹凸差距過大(凹陷深度大於4mm)、弧形鍋底、鍋底脚座高度高於或等於4mm或底部直徑超過120mm的鍋具。
【適合鍋具種類】 不銹鋼壺、鐵板、平底鍋、鐵鍋、鐵製烤盤及換糖磁鐵鍋等	【不適合鍋具種類】 鋁鍋、玻璃鍋、陶瓷鍋及銅鍋等

2. 除使用適合的鍋具、鍋具亦需放置在面板上加熱區的中央位置。
3. 在加熱過程中，鍋具發出“滋、滋”的聲音，這情況下是屬於正常現象，因不同鍋具工作時振動頻率不同而產生電磁聲，這對使用者不會造成任何安全害。

III、火力段數及功率分配說明：

兩邊爐區同一時間運作時，兩邊火力功率之和最高為7，當一邊火力功率增大，另一邊火力功率將自動下調，以保持火力功率之和不超過7。

左爐區		右爐區	
段數	火力功率(瓦)	段數	火力功率(瓦)
7	2800	0	0
6	2400	1	400
5	2000	2	800
4	1600	3	1200
3	1200	4	1600
2	800	5	2000
1	400	6	2400
0	0	7	2800

IV、警告事項：

- 陶瓷玻璃面板的發熱區利用平底鍋之熱力發熱。金屬用具如刀、叉、匙、蓋不能放置於爐面上，因為會令其受熱。為防止灼傷，不要觸摸此範圍。
- 空的鍋具切記不要放置於陶瓷玻璃面板發熱區內，否則會損壞電磁爐。
- 當食油加熱時，必須經常留意鍋具以防過熱及燒焦。
- 應使用火力段數3烹煮食油作油炸煮食，否則電磁爐會於烹煮約20分鐘後自關閉，LED數碼顯示區將顯示“E2”。

五、使用注意事項

I、安全注意事項

- 電磁爐上不要放置除加熱鍋具外的任何物體。
- 排氣口與吸氣口請勿插入鐵絲等異物，以避免發生觸電危險。
- 切勿堵塞排氣口。
- 請勿加熱沒有開封的罐頭類產品，因氣壓內積聚並會引起爆炸；導致身體受損或傷害。
- 請勿將爐具擺放在高溫環境中使用，並且這遠離火源。
- 不要放置一些會影響磁場的物品在電磁爐附近，如信用卡或磁片等。
- 時刻讓小朋友遠離電磁爐。
- 水源與電磁爐必須保持距離，以避免發生觸電危險及水份滲入電磁爐而產生功能上的干擾或故障。
- 水或類似液體留在電磁爐控制區域或附近表面，會令電磁爐產生功能上的干擾或故障。
- 這些設備不適合透過外部定時器或單獨的遙控系統進行操作。
- 本設備不適合身體、感官或精神能力較差或缺乏經驗和知識的人員（包括兒童）使用，除非有負責其安全的人員對他們進行有關使用本設備的監督或指導。
- 本設備旨在用於家庭和類似應用，例如：
 - 商店的員工廚房、辦公室和其他工作環境；
 - 農舍；
 - 酒店、旅館和其他住宅類型環境中的客戶；
 - 住宿加早餐類型的環境。

II、警告

- 禁止將電磁爐擺放在鐵製檯面或家用電器上工作（如鐵製廚櫃、消毒碗櫃、雪櫃、焗爐、洗碗碟機等）。
- 爐具工作時請勿將金屬物件，如刀、叉、勺、蓋等物件放在上面，防止被意外加熱。
- 爐具使用後，因受加熱鍋具高溫影響，加熱區留有餘溫頗高，請勿用手觸摸爐面加熱區。
- 電磁爐出現異常情況，如電源線破損等，須由代理商或被授權的維修專業人員進行更換維修。用戶不得自行更換拆卸，否則不予保修（因此產生的安全事故，本公司概不負責）。
- 如陶瓷玻璃面板破裂，請立即關機，拔掉電源插頭以防觸電。

六、日常保養注意事項

- 清洗電磁爐前，電磁爐應先冷卻。
- 爐具周圍請勿放置任何易燃、酸性或鹼性物品，以免酸、鹼對電磁爐中的電路板受腐蝕而影響電磁爐的壽命。
- 禁止使用蒸汽、腐蝕性或磨砂的清潔劑來清洗電磁爐。
- 請勿用水直接沖洗機體。
- 陶瓷玻璃面板的清潔：陶瓷玻璃面板髒污的時候，用布沾水輕輕擦拭，如擦不掉時用稀釋中性去污粉或清潔劑清潔後，再用濕布擦拭即可。
- 請勿用有機溶劑或含苯等化學藥品擦拭電磁爐，以免產生化學作用。切勿使用硬刷子刷洗爐面，使用鍋具底部時不要摩擦工作區的陶瓷玻璃面板表面，以免造成面板刮傷（工作區陶瓷玻璃面板表面刮傷不影響電磁爐的使用）。
- 定期清理進風口污漬與灰塵。
- 請確保移除器皿底部污漬。否則，污漬會燒焦後附在面板上。

七、產品規格

產品	雙頭電磁爐
型號	S8-2928IC
適用電源	AC220-240伏特/50赫茲
總輸出火力功率	2800瓦
爐身尺寸(闊 x 深 x 高)	740x 400x 65毫米
淨重量	10千克

八、維修指南

I、錯誤代碼

當電磁爐安裝或使用不當、供電不正常或電磁爐出現故障時，面板上的LED數碼顯示燈將顯示錯誤代碼。

錯誤代碼	錯誤原因
E0	電路故障
E1	鍋具未能感應
E2	機內溫度過高
E3	爐面溫度感測器失效
E4	IGBT溫度感測器失效
E5	供電電壓過高
E6	供電電壓過低

II、簡易故障的判別和排除

由於本機採用了最先進的微電腦檢測控制技術，所以在爐具工作中出現的一些現象並不意味有故障，請先按以下說明檢查。

現象	可能原因	解決方式
電磁爐不工作，指示“E1”。	1. 沒有鍋具放置至煮食爐區。 2. 使用不適用鍋具。	1. 放置合適鍋具。 2. 參考本說明書內「鍋具的選擇與使用」。
電磁爐工作一段時間，停機不工作，指示“E2”。	1· 電磁爐風扇進風口被堵。 2· 電磁爐風扇停轉 3· 電磁爐使用環境溫度過高，檢查一下周圍有否發熱器具 4· 被加熱物體溫升過高	1· 清潔、去除進風口堵塞物 2· 由專業維修人員修理 3· 改善環境條件 4· 消除幹燒等原因，待電磁爐加熱區表面冷卻後可繼續啟動工作
電磁爐不工作，指示“E3” “E4”。	溫度感測器故障	由專業維修人員修理

Sole Agent : Araytron Technology Limited
總代理 : 千中科技有限公司
Enquiry/查詢熱線 : + 852 2397 3066 Fax/傳真 : + 852 2397 3055
Website/網址 : www.garwoods.com.hk